

STOKES

A Monte Carlo radiative transfer code for polarization modeling

Frédéric Marin

Astronomical Institute of the Academy of Sciences of the Czech Republic

René W. Goosmann & Francesco Tamborra

Observatoire astronomique de Strasbourg, France



ASTRONOMICKÝ ÚSTAV

Akademie věd České republiky, v. v. i.



Observatoire astronomique
de Strasbourg

(Sir George) Stokes



Born : 13 August 1819

Died : 1 February 1903

Irish mathematician, physicist,
politician and theologian

Secretary, then president, of the
Royal Society

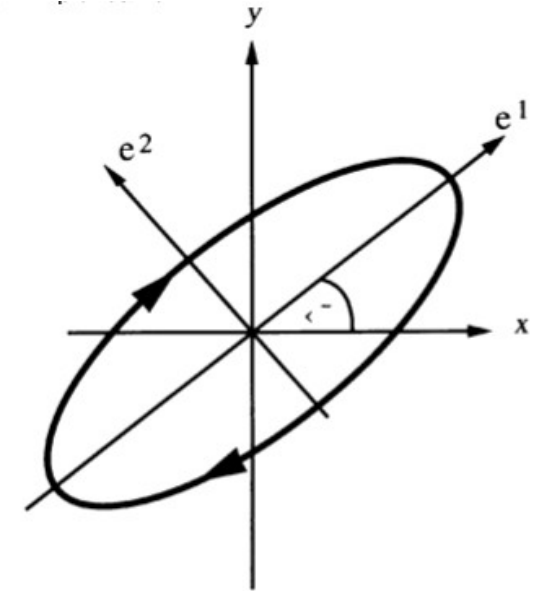

(Campbell – Stokes) Etched Glass Sundial



Contributions to science :

- Fluid dynamics
- Chemical analysis
- Light
- Fluorescence
- Polarization

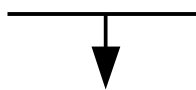

Stokes, G. G. 1852, Trans Cambridge Phil. Soc., 9, 339

(Code) Stokes

Monte Carlo code designed to perform three-dimensional radiative transfer

Written in C/C++ (imaging routine in IDL) – Stokes formalism

Created in 2004 to study the polarimetric signatures of Active Galactic Nuclei (AGN) in the optical / UV regime. Extended in the X-ray band (circa 2009)

Data cube of intensity+polarization as a function of 1- wavelength (spectroscopy), 2- sky position (imagery) and 3- time (variability)

Basic version publicaly available

(<http://www.stokes-program.info/>)

Can be adapted to a large panel of objects / sources :

- Red super-giant stars
- X-ray binaries
- Galactic Center
- AGN

home
manual
program
examples
dust models
source codes
scientific results
contact



George Gabriel Stokes (1819-1902)

STOKES
Modeling Radiative Transfer and Polarization

Observatoire
Astronomique
de
Strasbourg
René W. Goosmann

The STOKES computer program is a Monte Carlo radiative transfer code for modeling multi-wavelength polarization. It was designed to model astrophysical objects of various geometries and considers polarization induced by electron and dust scattering. If you are interested in polarization and radiative transfer you might want to follow the links on this page to find out more about STOKES. The code is freely available for use. We just ask if you publish results based on STOKES computations that you refer to the [Goosmann & Gaskell \(2007\)](#) paper describing the code.

A NEW VERSION 1.2 OF STOKES WILL APPEAR HERE SHORTLY!

--> Check out the [manual](#) to get an introduction to the capabilities of the program and learn how to run it.

--> You may download compiled versions of the [program](#) for Linux and Windows.

--> [Examples](#) for the input files and pre-computed [dust models](#) are helpful to get used to running the code.

--> If you would like to adjust the program to your personal needs and compile it yourself you may obtain the C++ [source codes](#).

--> Find out about [scientific results](#) obtained with STOKES.

STOKES was written by **René W. Goosmann** who is now at the Observatoire Astronomique de Strasbourg, France. If you have questions or comments about the code, please [contact](#) him.

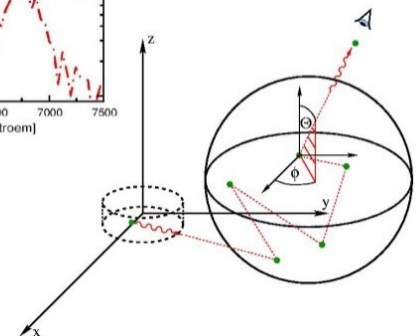
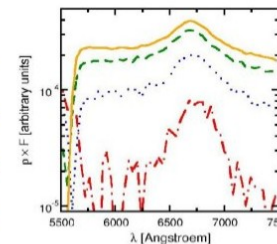

Publications

Main papers:

- Goosmann & Gaskell, 2007, A&A, 465, 129
- Marin, Goosmann, Gaskell, Porquet & Dovciak, 2012, A&A, 548, A121

Various utilisations of STOKES so far:

- Exploring the Unified Model of AGN
- Off-axis irradiation and broad emission lines polarization in AGN
- Probing the origin of the iron $K\alpha$ line around stellar and supermassive black holes
- Spectropolarimetric signatures from disk-born outflows
- Modelling the complex geometry of « changing look » AGN
- Constraining the layout of circumnuclear clouds in the Galactic center

Total (May 2014):

- 25 articles (refereed papers and proceedings)
- 96 citations

A photon journey

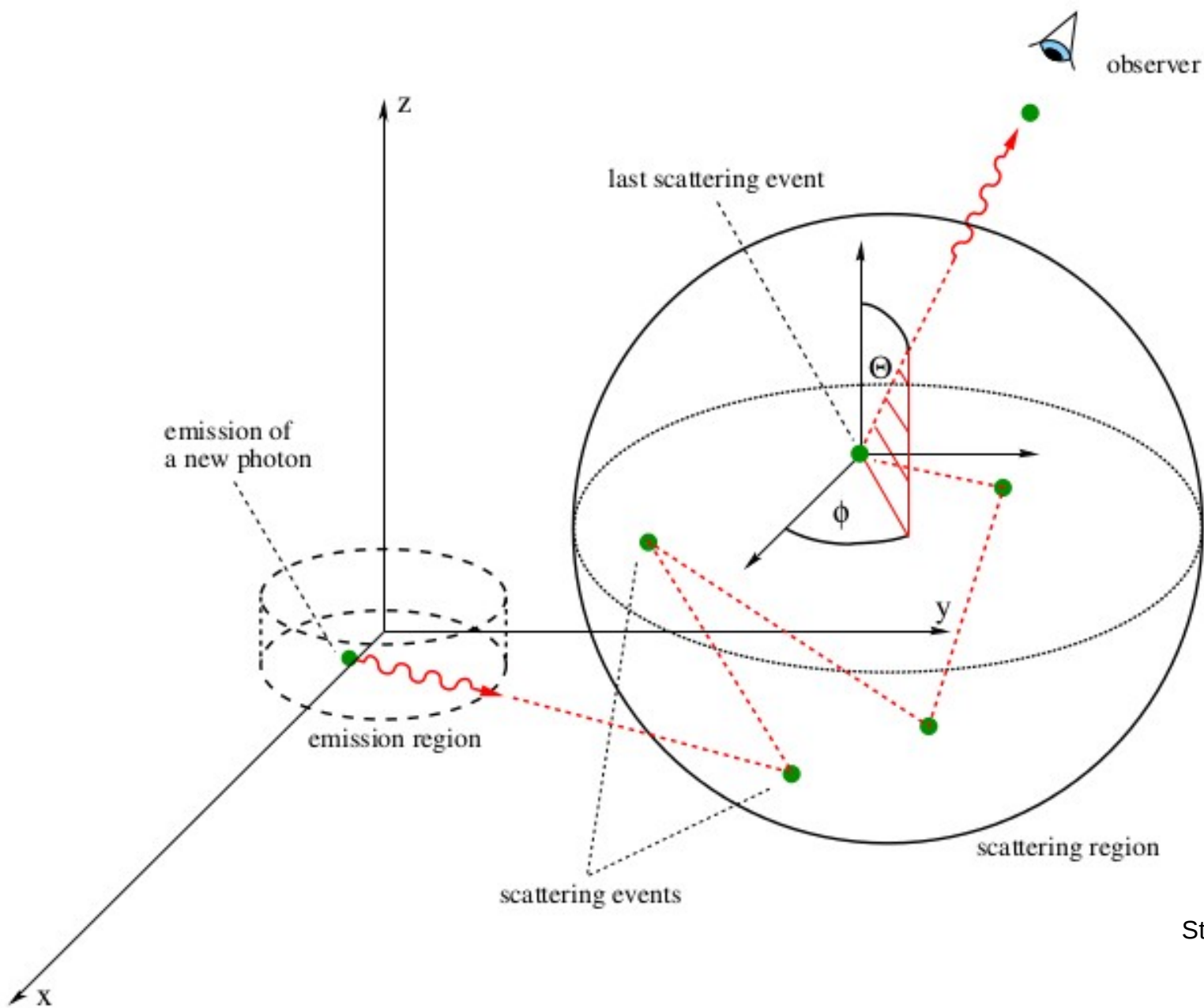

Emission regions

SED:

- Power-law
- (multiple) black-body emission

Morphology:

- point-like
- cylinder
- slab
- double-cone
- torus
- segments

Waveband/energy band:

- optical/UV: 1400 – 10 000 Å
- X-rays: 0.8 – 300 keV

Parallel computing

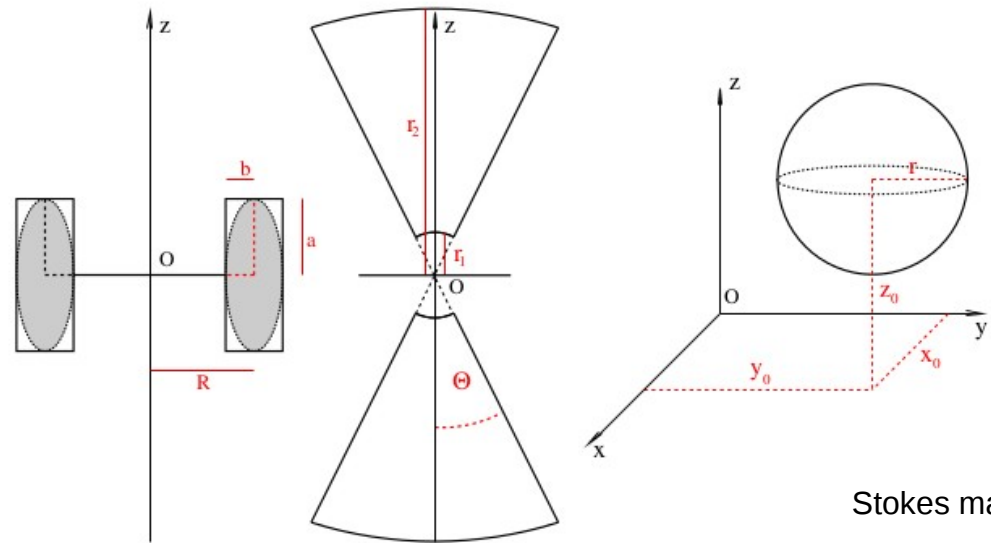

Stokes manual

Impact of statistics

Importance of Random Number Generation (RNG)
in radiative transfer codes

Usual RNG: Linear Congruential Generators (LCG)

- fast and efficient only for short series
($<10^7$ photons)
- loop back on series of values it has
sampled before

$$x_0 = 585 \quad x_{n+1} \rightarrow (29 x_n - 108) \bmod 574$$

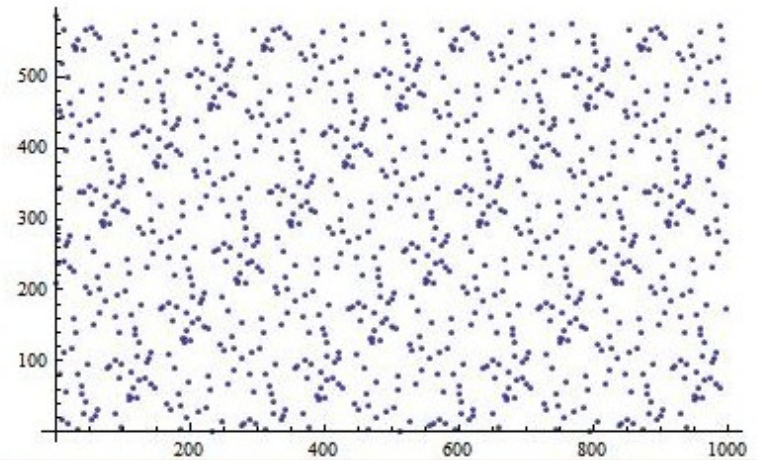

RNG implemented in STOKES: Mersenne Twister Generator (MTG)

- generates pseudo-random numbers
using a so-called twisted generalized
feedback shift register
- very high period of $2^{19937} - 1$
- provides a 623-dimensional
equidistribution up to an accuracy
of 32 bits
- passes the “Diehard” tests
Marsaglia (1985)

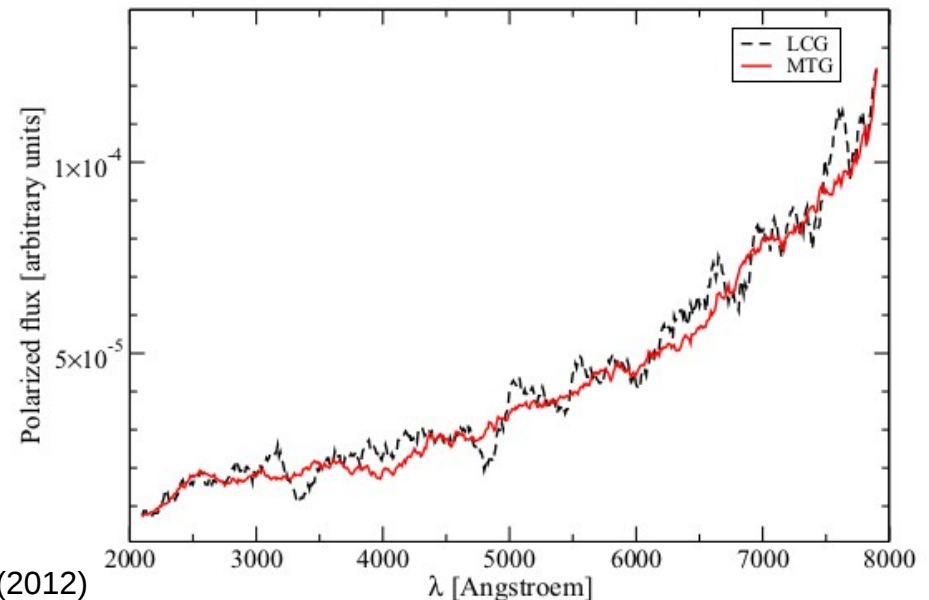

Reprocessing regions

Composition:

- Dust (user-defined mixture)
- Electrons
- Atoms (from H to Ni)

Morphology:

- cylinder
- slab
- double-cone
- torus
- clouds
- disk-born winds

Processes:

- Thomson/Compton/Mie scattering
- Radiative recombination
- Photoionization / Fluorescence
- Dust / atomic absorption

3D velocity is implemented

Multiple-scattering (crucial for circular polarization)

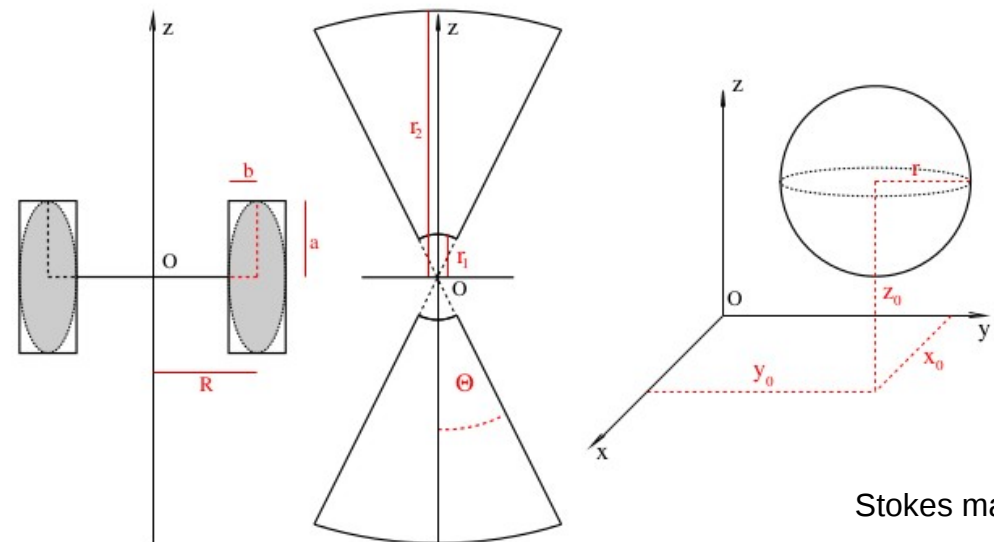

Stokes manual

Results

Photons stored in terms of Stoke's vector (I,Q,U,V) + t

Results processed with the module called ANALYZE

- Total flux
- Percentage of total polarization (linear + circular)
- Polarized flux
- Polarization angle
- Percentage of circular polarization
- Ellipticity
- Polarization map
- Time-lag

Example:

- Phenomenologically-based structure (Elvis 2000)
- Radiation-driven wind
- Bi-phased (WHIM / dust)
- Emission region off-axis

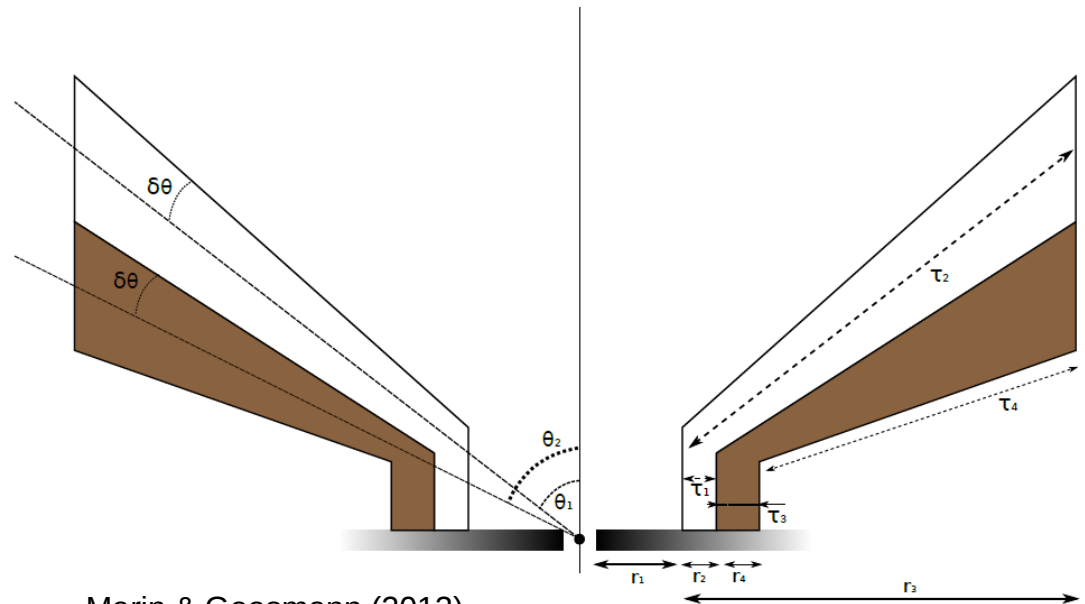

Marin & Goosmann (2013)

Results

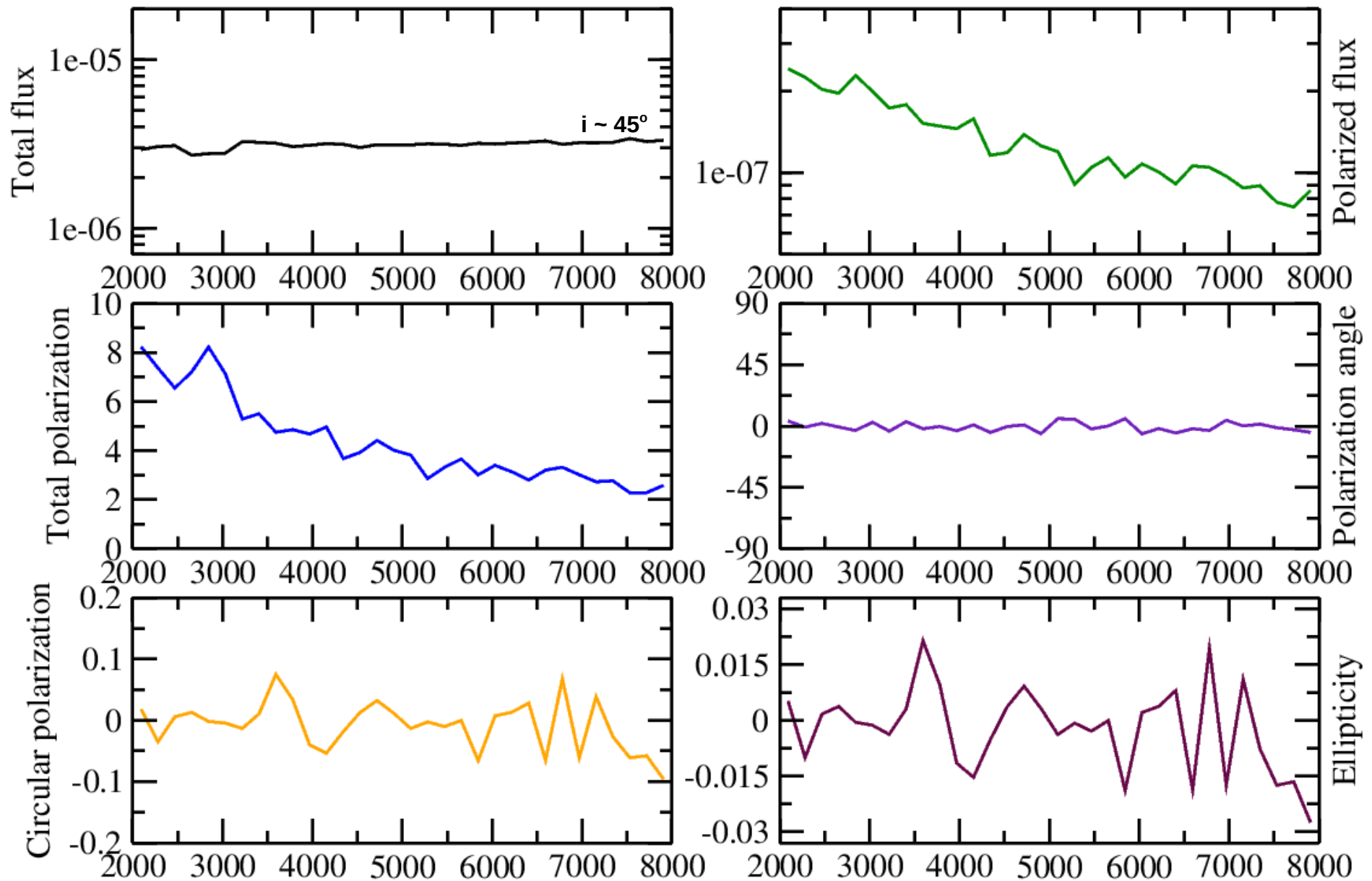

Results

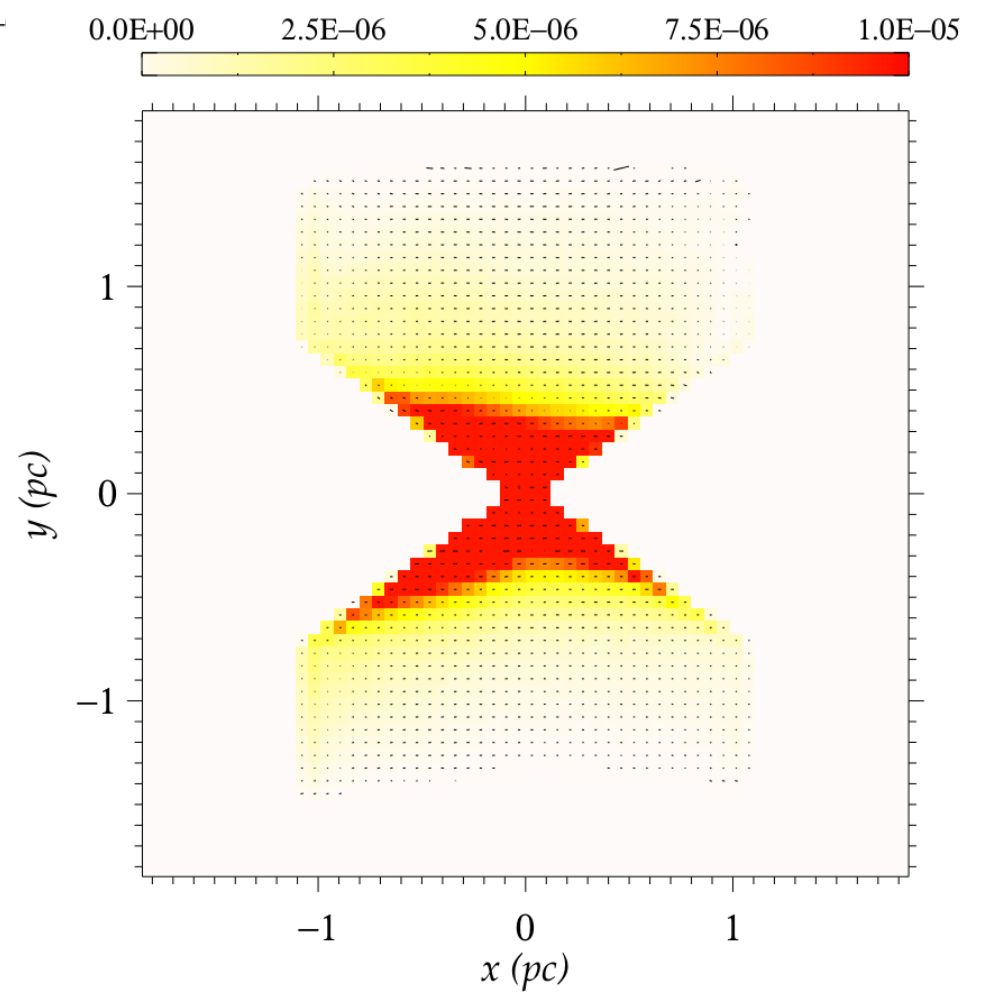
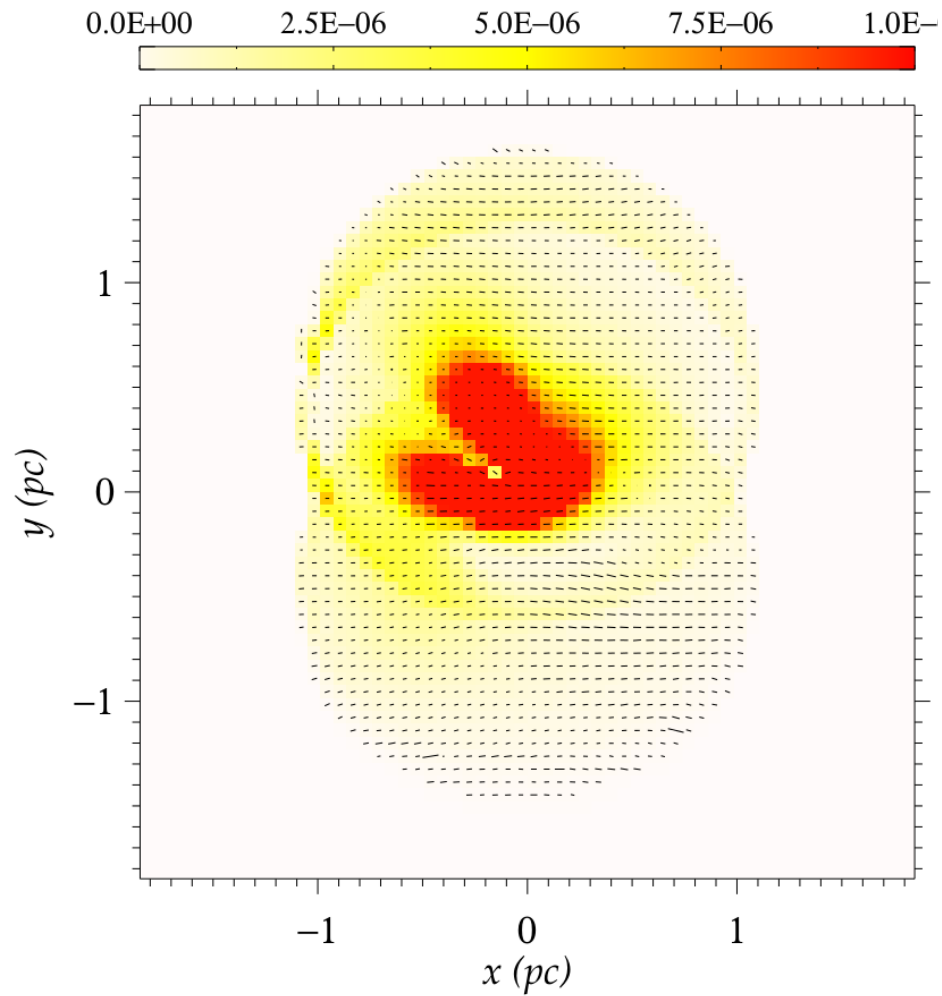

(Mie scattering removed)

Probing (unusual) AGN with polarimetry

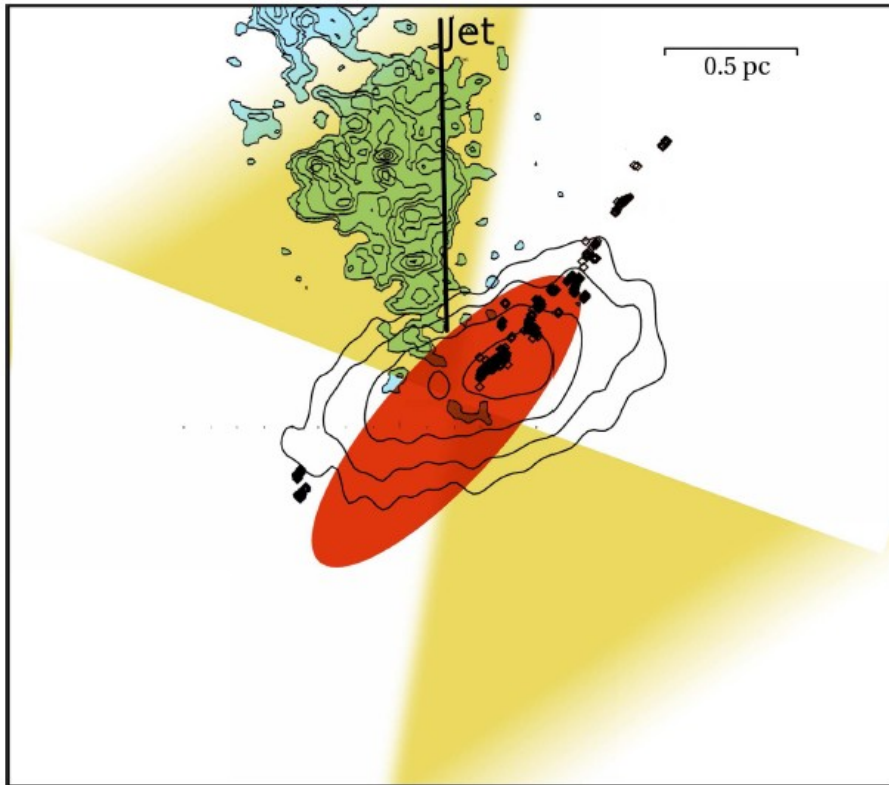

Raban et al, (2009)

NGC 1068 = one of the best examples of archetypal Seyfert-2

Compact dusty torus: 0.45×1.35 pc

Principal hypothesis: the polar outflows sustain the same half-opening angle as the dusty torus

Raban et al. (2009) → polar winds (represented as a bi-conical structure) are inclined with respect to the obscuring torus axis

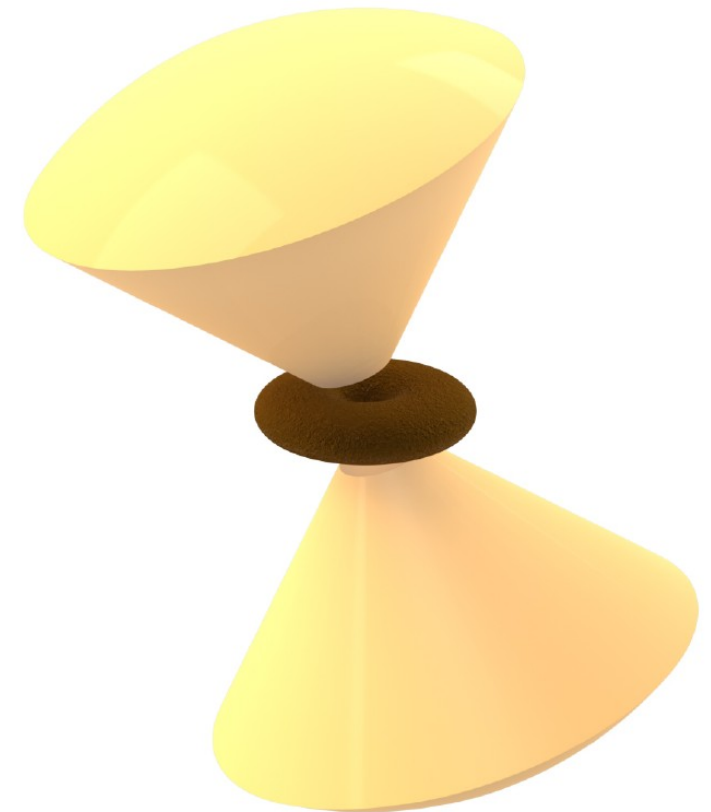

Marin, Goosmann & Dovciak (2012)

Probing (unusual) AGN with polarimetry

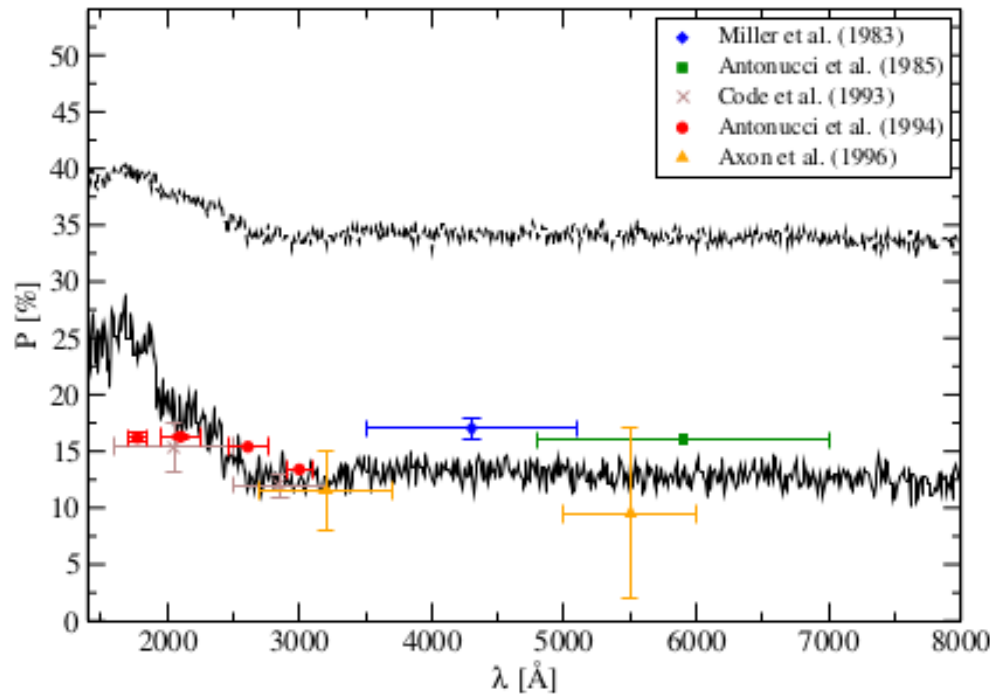

Marin et al, (in prep.)

Polarization degree and polarization angle as 2 independent and complementary informations

Constraining the 3D geometry of the tilted outflows with polarimetry

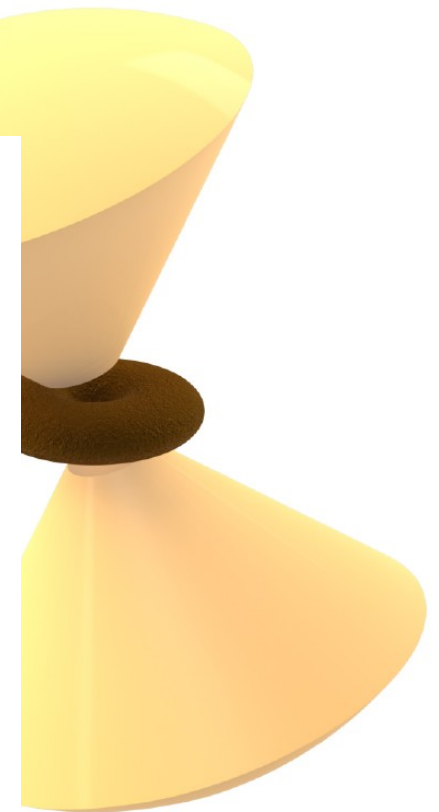
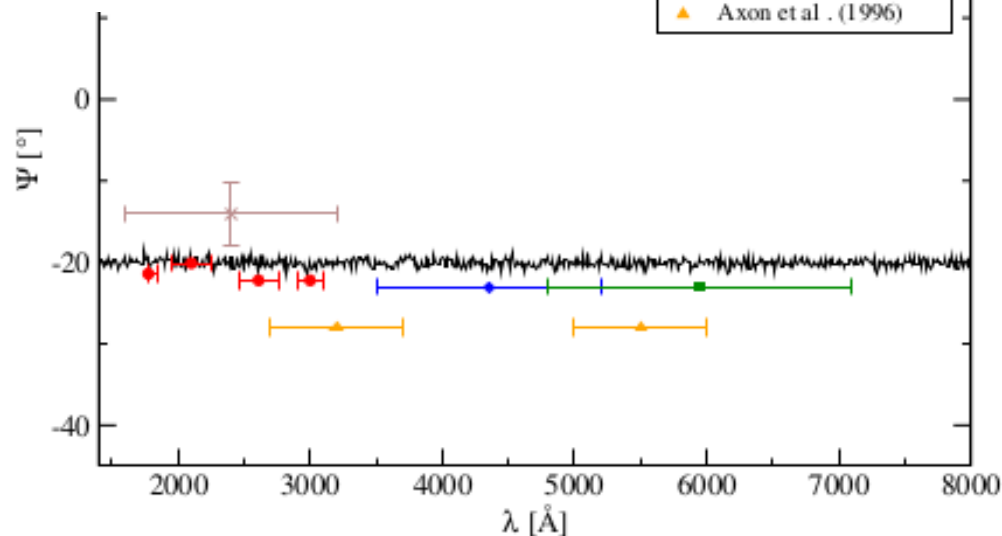

Multi-wavelength polarimetry

To probe the geometry and kinematics of emission and scattering regions, it is important to provide consistent and simultaneous polarization models in the optical/UV and the X-ray band

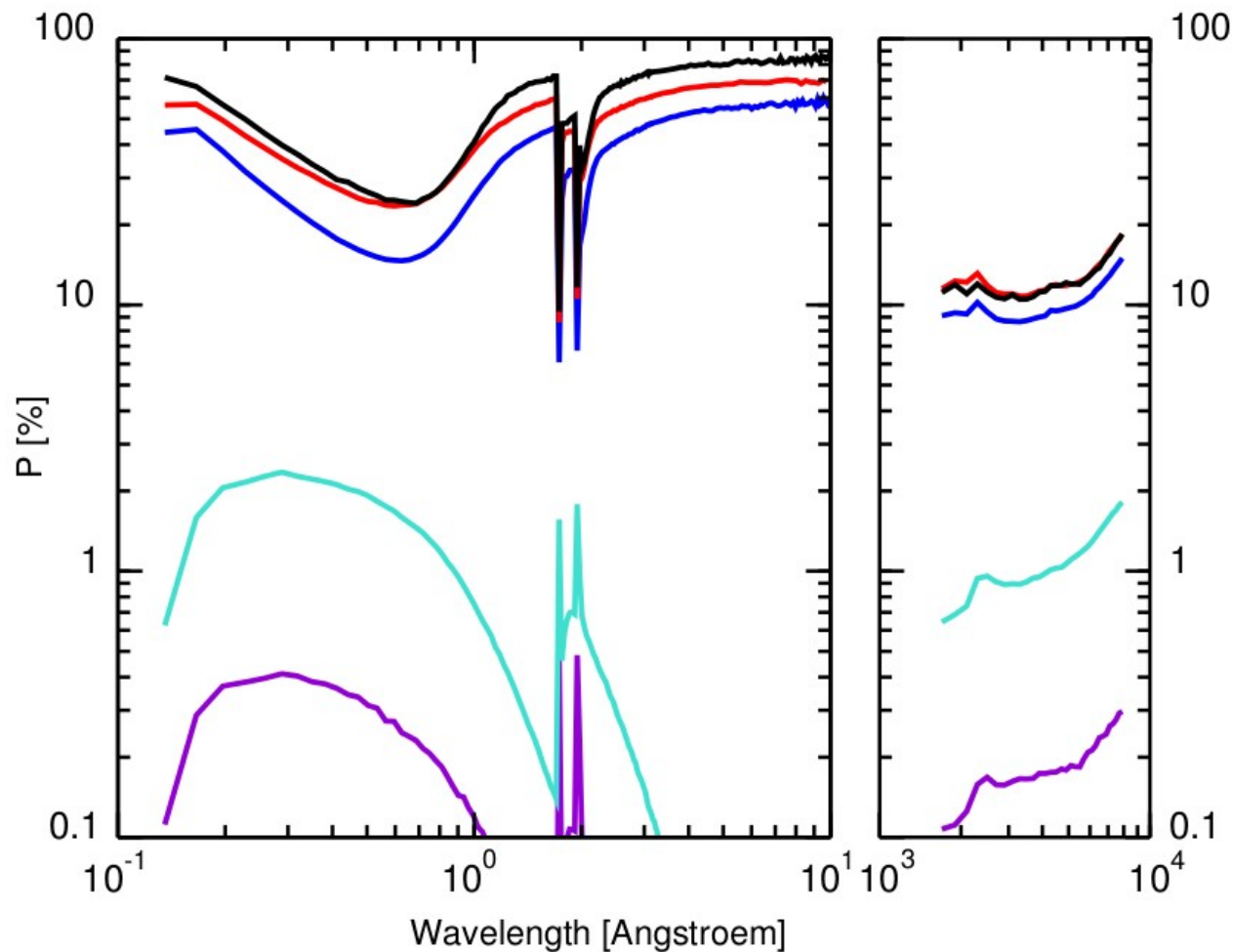

Promoting X-ray polarimetry

The actual context of the Galactic Center

- 3D location of Sgr A*, Sgr B2, Sgr C ... ?
- Are Sgr B2 and Sgr C reflecting past Sgr A* emission ?

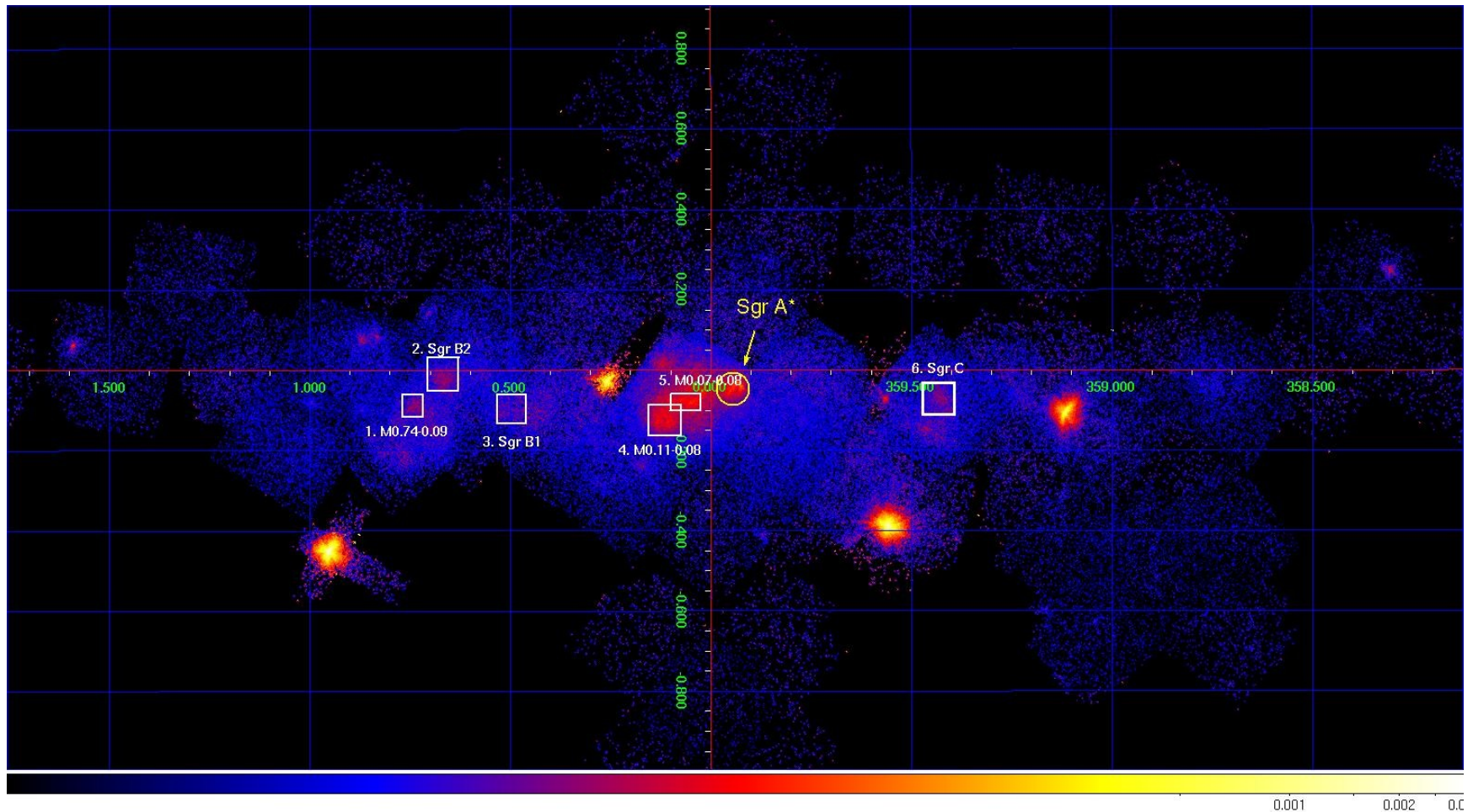

JAXA – Suzaky X-ray map of the GC

Promoting X-ray polarimetry

The actual context of the Galactic Center

- 3D location of Sgr A*, Sgr B2, Sgr C ... ?
- Are Sgr B2 and Sgr C reflecting past Sgr A* emission ?

X-ray polarimetry can bring answers

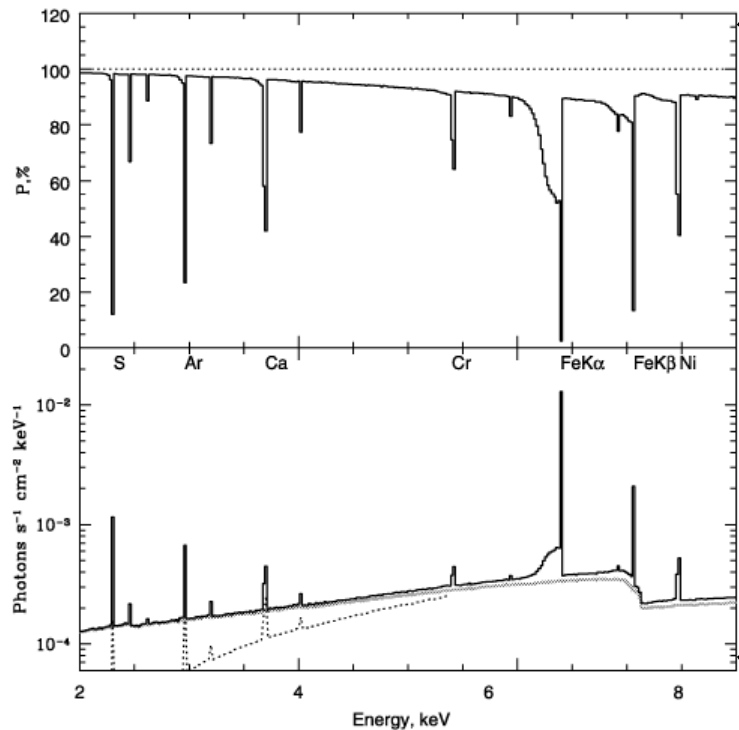

Churazov & Sunyaev (2002)

Marin et al. (2014)

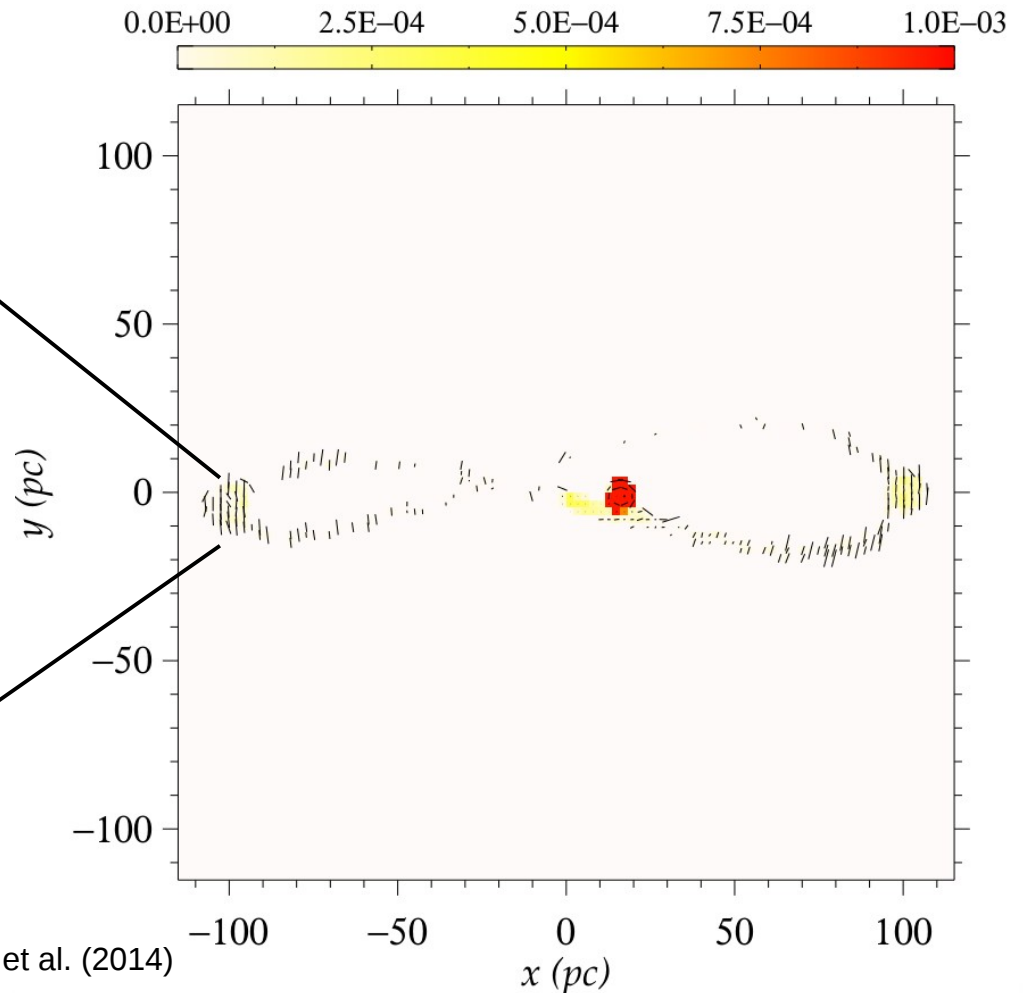

x (pc)

Synergy with other codes

Potential coupling with :



MoCa – F. Tamborra, G. Matt, S. Bianchi

IDL code (interactive and vectorized), modular and fully special relativistic (Klein-Nishina cross-section, Juttner distribution ...)

→ to include special relativity



SKIRT – M. Stalevski, M. Baes

3D Monte Carlo radiative transfer code (photon packages)

Temperature, kinematic, adaptative grid, variety of reprocessing geometry

→ to include infrared mechanisms

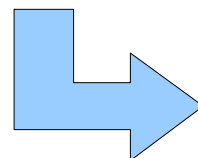

Polarization to be implemented